



TH	THAILAND
----	----------

Diagram / Parts List

DHP453

CORDLESS PERCUSSION-DRIVER DRILL



(TH) DHP453 / CORDLESS PERCUSSION-DRIVER DRILL

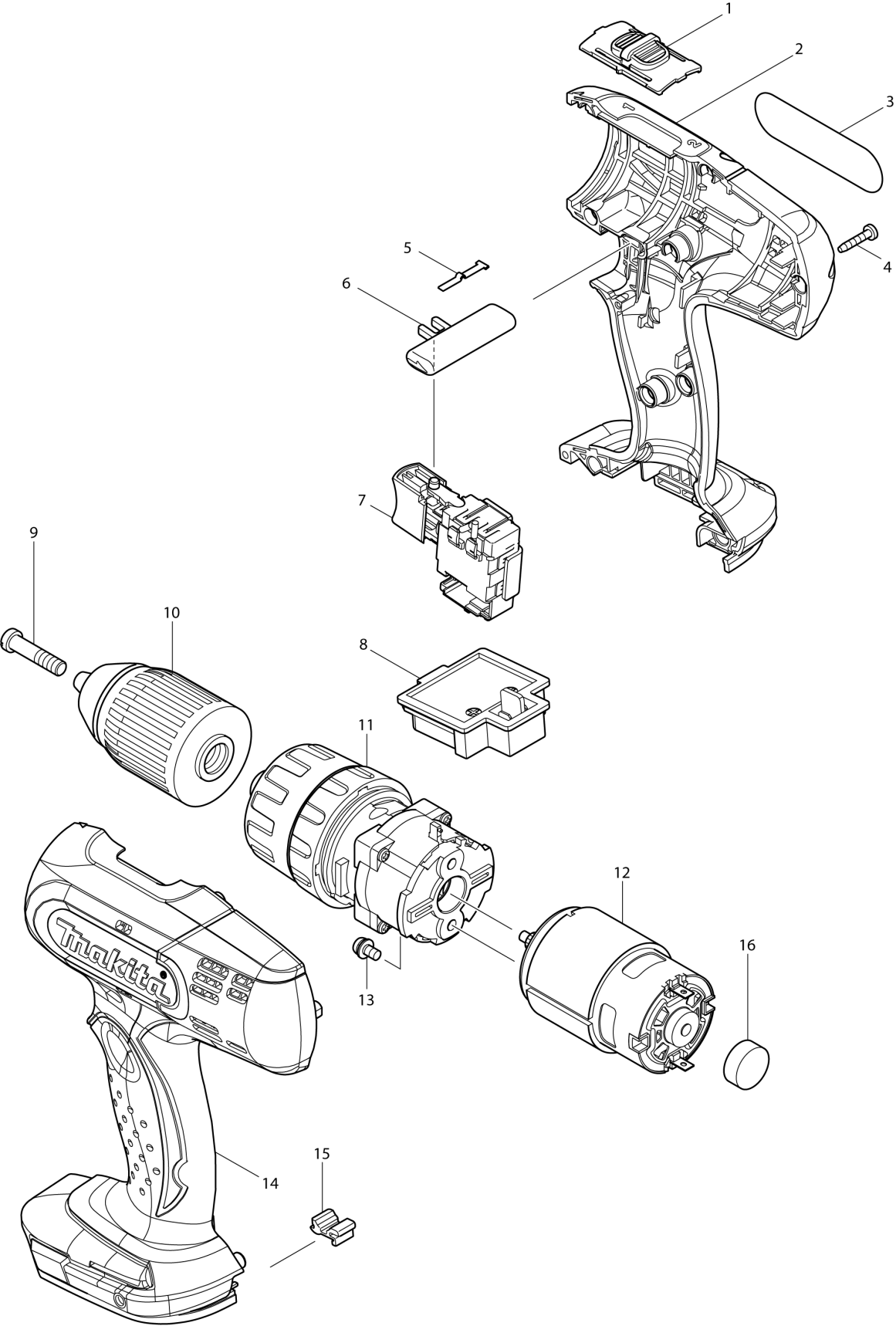

TH	THAILAND
-----------	-----------------

DHP453 / CORDLESS PERCUSSN-DRIVER DRILL

Item	Sub	Parts No.	Parts Description	Qty	I/C	E/C No.	Close No.	Remark
001		125310-5	SPEED CHANGE LEVER ASS'Y	1				
	C10	231433-0	COMPRESSION SPRING 4	2				
002		187363-2	HOUSING SET	1				
	C10	263005-3	RUBBER PIN 6	2				
	D10		INC. 14					
003		815J03-9	DHP453 NAME PLATE	1				
004		266130-9	TAPPING SCREW BIND PT 3X16	9				
005		232182-2	LEAF SPRING	1				
006		419250-0	F/R CHANGE LEVER	1				
007		632A24-0	SWITCH UNIT	1				
008		643852-2	TERMINAL	1				
009		251468-5	- FLAT HEAD SCREW M6X22	1				
010		766004-9	KEYLESS DRILL CHUCK 13	1				
011A		125485-0	GEAR ASS'Y	1			A7840	
011B		125485-0	GEAR ASS'Y	1			A7840	
011C		125485-0	GEAR ASS'Y	1			A7840	
011D		125485-0	GEAR ASS'Y	1			A7840	
011-1A		125485-0	GEAR ASS'Y	1	O	A7840		
011-1B		125485-0	GEAR ASS'Y	1	O	A7840		
011-1C		125485-0	GEAR ASS'Y	1	O	A7840		
011-1D		125485-0	GEAR ASS'Y	1	O	A7840		
011-1F		125485-0	GEAR ASS'Y	1				
011-1G		125485-0	GEAR ASS'Y	1				
012		629834-8	DC MOTOR	1				
013		911108-4	PAN HEAD SCREW M4X8	2				
014		187363-2	HOUSING SET	1				
	C10	263005-3	RUBBER PIN 6	2				
	D10		INC. 2					
015		424476-1	CUSHION	1				
016		421940-3	CAP	1				
A01		784636-0	+ - BIT 2-65	1				
A02A		***DC18RC	DC18RC FAST CHARGER	1				
A02B		***DC18SD	DC18SD BATTERY CHARGER	1				
A02D		***DC18SD	DC18SD BATTERY CHARGER	1			DF610	
A02F		***DC18SD	DC18SD BATTERY CHARGER	1			DF610	
A02G		***DC18SD	DC18SD BATTERY CHARGER	1			DF610	
A02-1D		***DC18SD	DC18SD BATTERY CHARGER	1	O	DF610		
A02-1F		***DC18SD	DC18SD BATTERY CHARGER	1	O	DF610		
A02-1G		***DC18SD	DC18SD BATTERY CHARGER	1	O	DF610		
A03A		196015-4	BATTERY BL1830 SET	2			A5588	
A03B		196013-8	BATTERY BL1815 SET	2				
A03F		199283-8	BATTERY BL1830B SET	1			D0159	
A03-1A		196015-4	BATTERY BL1830 SET	2	O	A5588	B2535	
A03-1D		196448-3	BATTERY BL1815N SET	2			C1574	
A03-1F		199283-8	BATTERY BL1830B SET	1	<	D0159		
A03-1G		199283-8	BATTERY BL1830B SET	2			D0159	
A03-2A		197600-6	BATTERY BL1830B SET	2	<	B2535	C2803	
A03-2D		196235-0	BATTERY BL1815N SET	2	O	C1574	C2803	
A03-2G		199283-8	BATTERY BL1830B SET	2	<	D0159		
A03-3A		199283-8	BATTERY BL1830B SET	2	<	C2803	D0159	
A03-3D		199284-6	BATTERY BL1815N SET	2	<	C2803	D0158	
A03-4A		199283-8	BATTERY BL1830B SET	2	<	D0159		
A03-4D		199284-6	BATTERY BL1815N SET	2	<	D0158		
A04A		450128-8	BATTERY COVER	1				
A04B		450128-8	BATTERY COVER	1				
A04D		450128-8	BATTERY COVER	1				
A04G		450128-8	BATTERY COVER	1				
A05A		158777-2	PLASTIC CARRYING CASE	1				
	C10	163455-1	LATCH	2				
	C20	419360-3	HANDLE	1				
A05B		158777-2	PLASTIC CARRYING CASE	1				
	C10	163455-1	LATCH	2				
	C20	419360-3	HANDLE	1				
A05D		158777-2	PLASTIC CARRYING CASE	1				
	C10	163455-1	LATCH	2				

A:DHP453RFE(H)
 B:DHP453SHE(H)
 C:DHP453Z(N)
 D:DHP453SYE(H)
 F:DHP453SF1J(H)
 G:DHP453FX13(H)

Interchange
 O : Yes
 X : No
 < : the new part can be substituted for the current.
 > : the current part can be substituted for the new.
 S : Interchangeable as a set.

