



TH	THAILAND
----	----------

Diagram / Parts List

MLT100

TABLE SAW 255MM



(TH) MLT100 / TABLE SAW 255MM

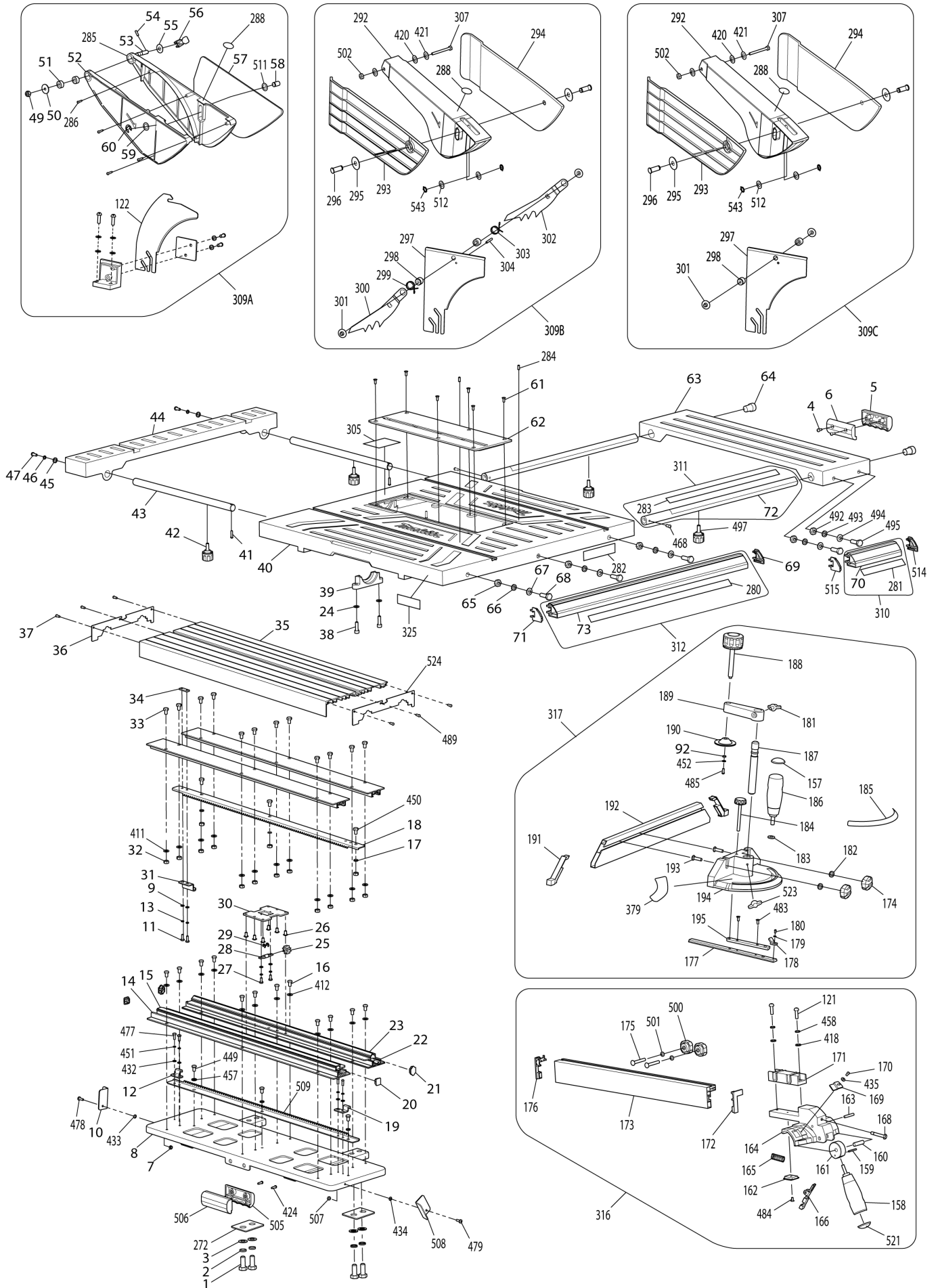

(TH) MLT100 / TABLE SAW 255MM

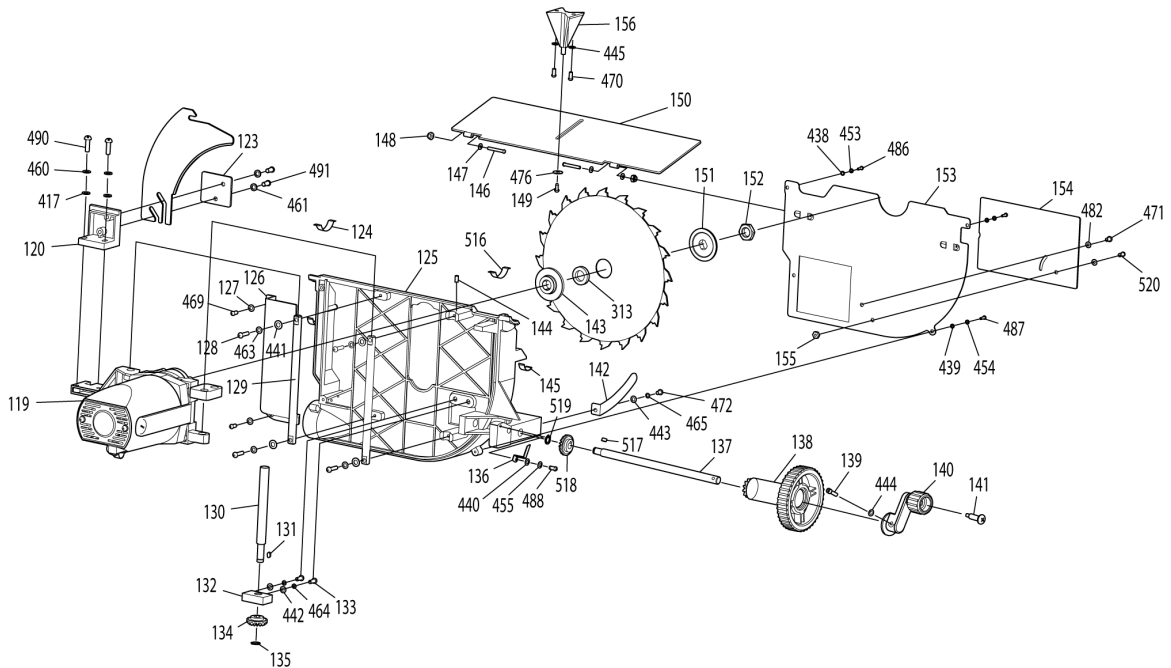
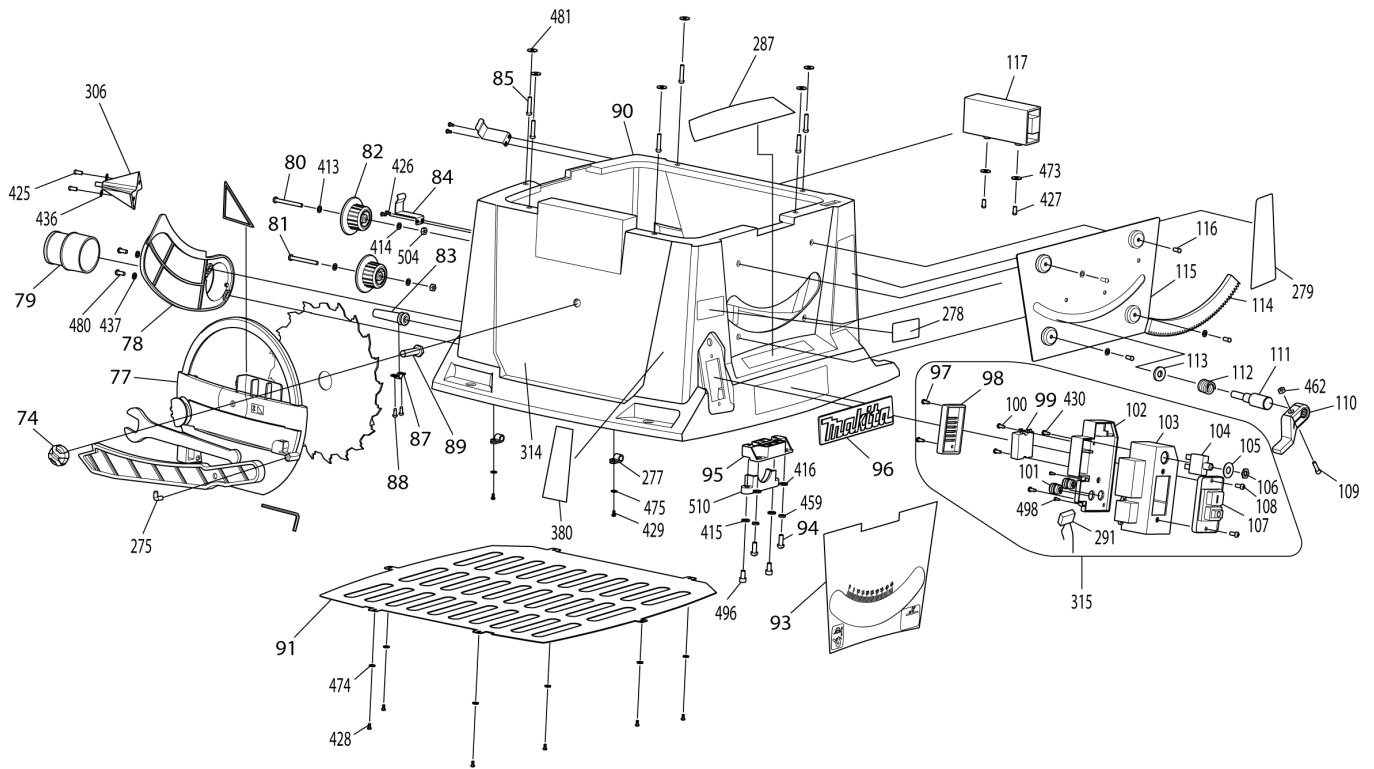

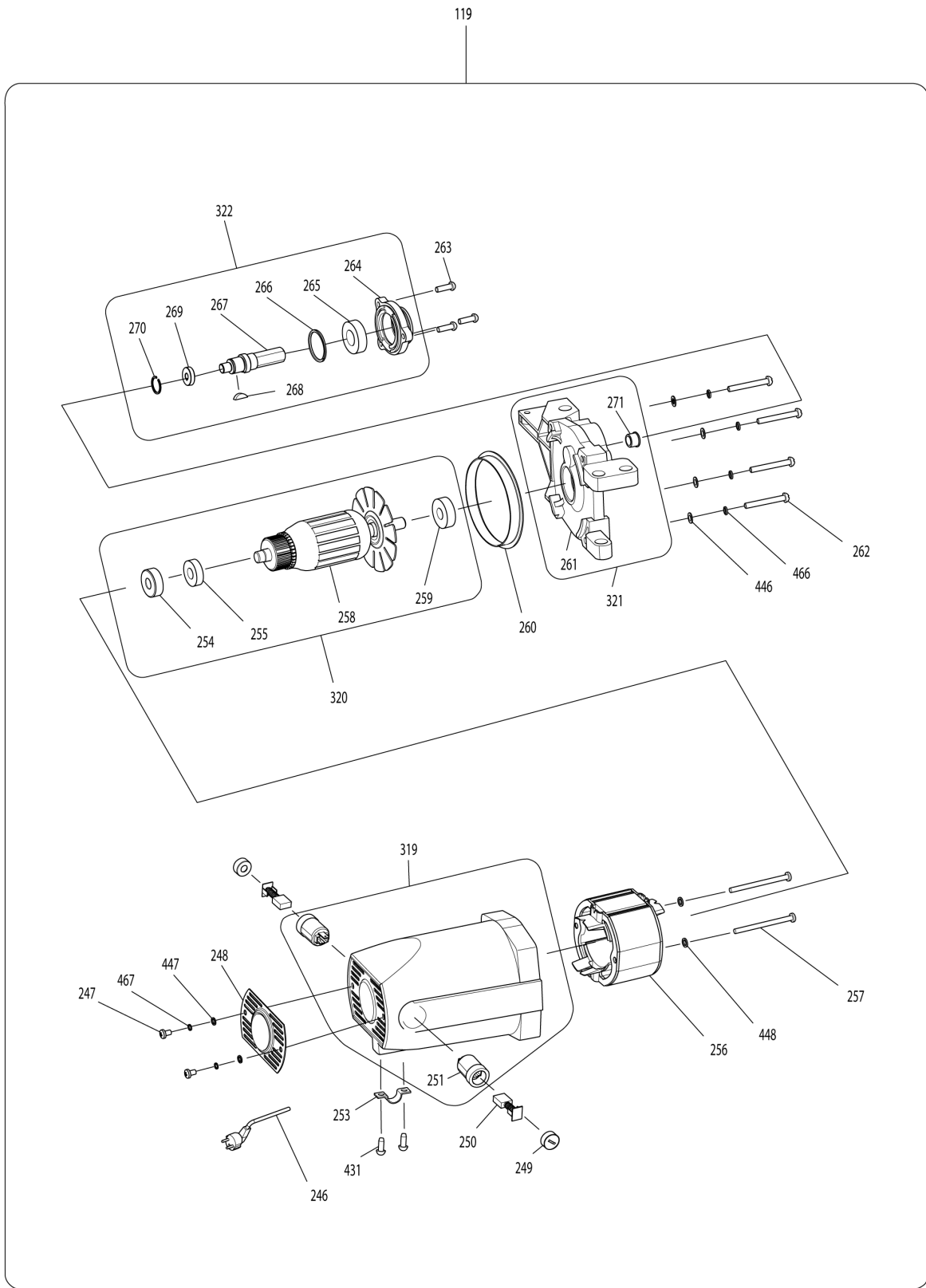

(TH) MLT100 / TABLE SAW 255MM

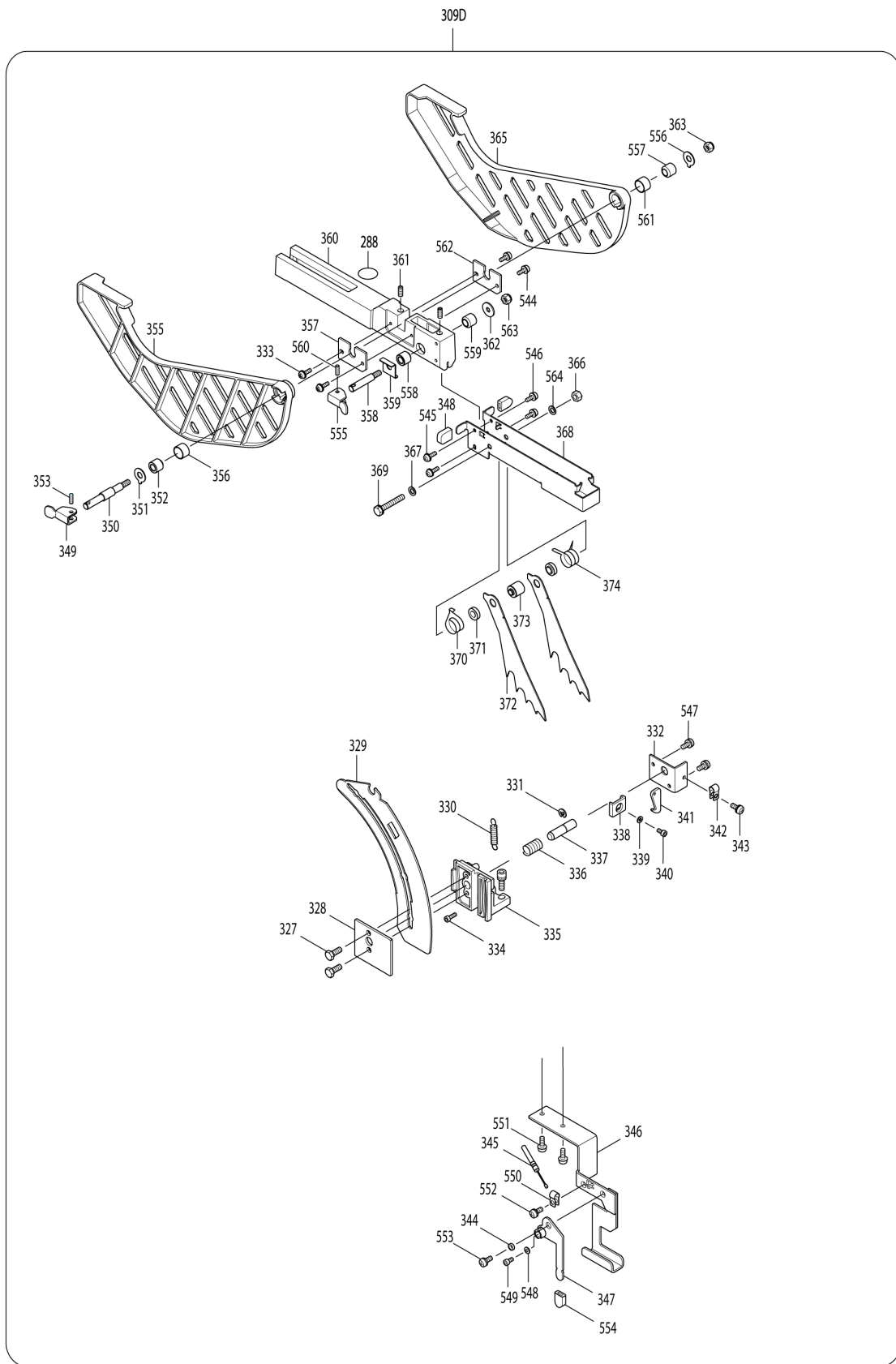

(TH) MLT100 / TABLE SAW 255MM

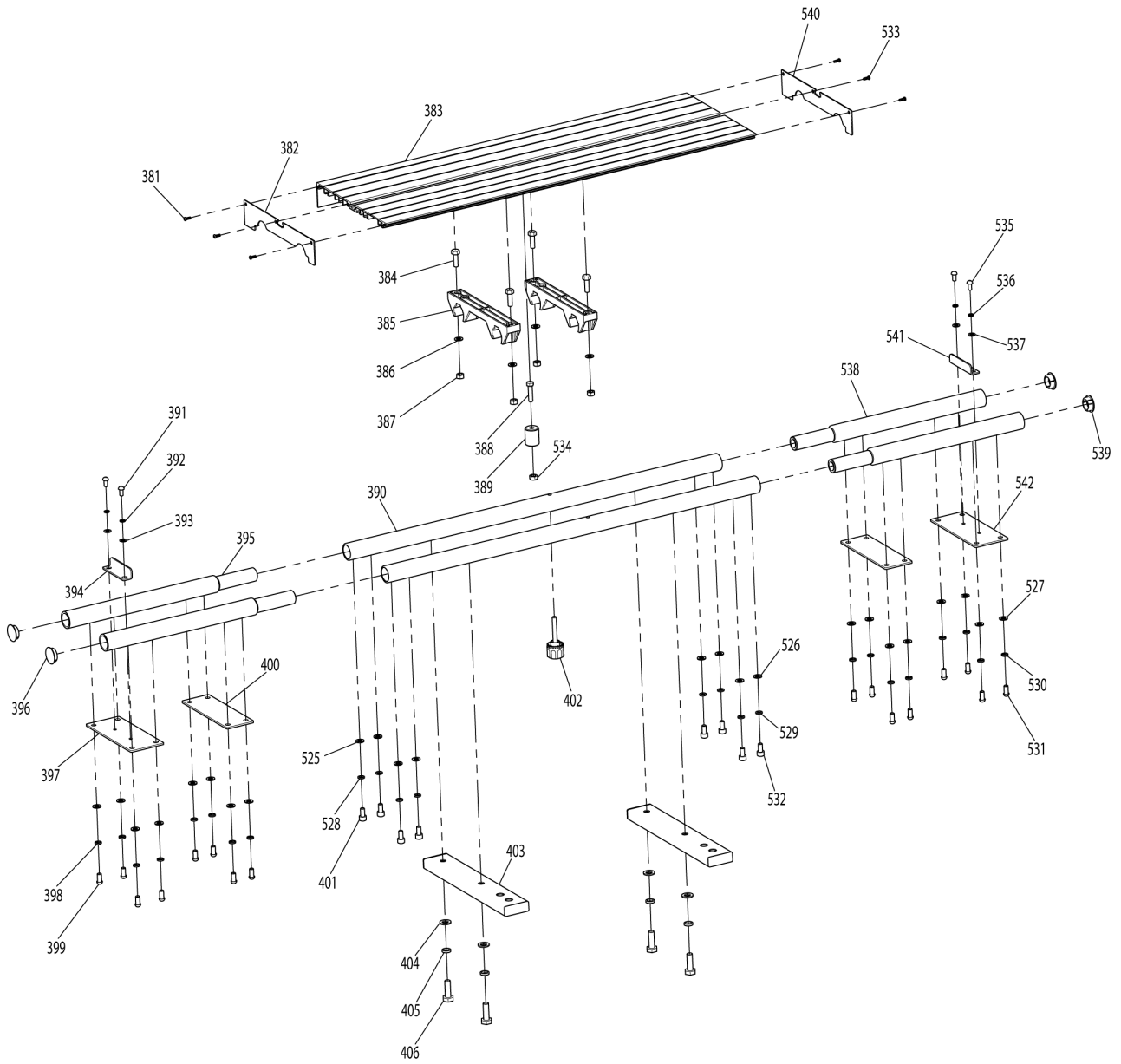

TH	THAILAND
----	----------

MLT100 / TABLE SAW 255MM

Item	Sub	Parts No.	Parts Description	Qty	I/C	E/C No.	Close No.	Remark
001		JM27000001	HEX BOLT M10X35	4				
002		JM27000002	SPRING WASHER 10	4				
003		JM27000003	FLAT WASHER 10	4				
004		JM27000004	SELF TAPPING SCREW ST3.9X12	2				
005		JM27000005	GRIP (OUTSIDE)	1				
006		JM27000006	GRIP (INSIDE)	1				
007		JM27000007	HEX LOCK NUT M4	1				
008		JM27000008	SLIDE TABLE BASE	1				
009		JM27000009	FLAT WASHER 4	2				
010		JM27000010	SLIDE TABLE STOPPER	1				
011		JM27000011	PAN HEAD SCREW M4X12	2				
012		JM27000012	SLIDE LIMITER LOWER REAR	1				
013		JM27000013	SPRING WASHER 4	2				
014		JM27000014	SQUARE SLIDER RAIL OUTSIDE	2				
015		JM27000015	SLIDING FLAT RAIL	1			Y08128	
016		JM27000016	PAN HEAD SCREW M6X10	1			Y08128	
016-1		JM27000016	PAN HEAD SCREW M6X10	12	<	Y08128		
017		JM27000017	SPRING WASHER 6	3			Y05879	
017-1		JM27000024	FLAT WASHER 6	3	X	Y05879		
018		JM27000018	RACK FOR SLIDE TABLE	1				
019		JM27000019	SLIDE LIMITER LOWER FRONT	1				
020		JM27000020	SQUARE SLIDER RAIL END CAP	2				
021		JM27000021	V-SLIDER RAIL END CAP	2				
022		JM27000022	V-SLIDER RAIL OUTSIDE	2				
023		JM27000023	SLIDING RAIL	1			Y08128	
024		JM27000024	FLAT WASHER 6	2				
025		JM27000025	PINION GEAR FOR SLIDE TABLE	1				
026		JM27000026	RIVET 5X9	6			Y08128	
027		JM27000027	PAN HEAD SCREW M4X10	2				
028		JM27000028	PINION GEAR AXLE	1				
029		JM27000029	E SHAPE RETAINING RING 6	1			Y08128	
029-1		JM27000029	E SHAPE RETAINING RING 6	2	<	Y08128		
030		JM27000030	SLIDING LIMITED PLATE	1			Y08128	
031		JM27000031	SLIDE LIMITER LOWER REAR	1				
032		JM27000032	HEX NUT M6	12				
033		JM27000033	HEX BOLT M6X10	12				
034		JM27000034	PLATE NUT M4	1				
035		JM27000035	SLIDING TABLE	1				
036A		JM27000036	SLIDING TABLE COVER	1				
037		JM27000037	TAPPING SCREW ST3.9X8	3				
038		JM27000038	PAN HEAD SCREW M6X16	2				
039		JM27000039	FIX BRACKET FOR BLADE CASE	1				
040A		JM27000040	MAIN TABLE A	1			Y06354	
040A1		JM270000430	MAIN TABLE A	1	<	Y06354	Y08128	
040A2		JM00000002	MAIN TABLE A	1	<	Y08128	Y08755	
040A3		JM00000267	MAIN TABLE A	1	O	Y08755		
041		JM27000042	PAN HEAD SCREW M5X10	2			Y08128	
041-1		JM27000167	PAN HEAD SCREW M5X12	2	X	Y08128		
042		JM27000043	KNOB BOLT M6X20	2				
043		JM27000044	SLIDE SHAFT 330	2				
044A		JM27000045	REAR EXTENSION TABLE	1			Y05417	
044A1		JM27000046	REAR EXTENSION TABLE ASSEMBLY	1	O	Y05417	Y08972	
044A2		JM00000262	REAR EXTENSION TABLE	1	X	Y08972		
045		JM27000047	WASHER 5 (L)	2				
046		JM27000048	SPRING WASHER 5	2				
047		JM27000049	CROSS HEAD SCREW M5X14	2			Y08128	
047-1		JM27000167	PAN HEAD SCREW M5X12	2	X	Y08128		
049		JM27000051	HEX LOCK NUT M6	1				
050		JM27000055	WASHER 6 (21.5)	1				
051		JM27000056	FIX PLATE	2				
052		JM27000057	LEFT GUARD	1				
053		JM27000058	CONNECTION BOLT	1				
054		JM27000059	PIN 4X12	1				
055		JM27000060	WASHER	1				
056		JM27000061	QUICK FIXING LEVER	1				

A:

Interchange
O : Yes
X : No
< : the new part can be substituted for the current.
> : the current part can be substituted for the new.
S : Interchangeable as a set.

TH	THAILAND
----	----------

MLT100 / TABLE SAW 255MM

Item	Sub	Parts No.	Parts Description	Qty	I/C	E/C No.	Close No.	Remark
057		JM27000062	SIDE PROTECTION PLATE	1				
058		JM27000063	PIN 10X21.5	1				
059		JM27000064	FLAT WASHER 10	1				
060		JM27000065	RING 10	1				
061		JM27000066	FLAT HEAD SCREW M4X8	6				
062A		JM27000067	TABLE INSERT (PLASTIC)	1				
063A		JM27000068	RIGHT EXTENSION TABLE	1			Y08755	
063A1		JM00000263	RIGHT EXTENSION TABLE	1	O	Y08755		
064		JM27000069	HEX SOCKET HEAD BOLT M14X20	2				
065		JM27000070	HEX NUT M8	3				
066		JM27000071	SPRING WASHER 8	3				
067		JM27000072	FLAT WASHER 8	3				
068		JM27000073	SQUARE NECK BOLT M8X25	3				
069		JM27000074	FRONT RAIL END CAP RIGHT	1				
070		JM27000075	FRONT RAIL FOR RIGHT EX-TABLE	1				
071		JM27000078	FRONT RAIL END CAP LEFT	1				
072		JM27000079	SLIDING BAR A	2			Y06354	
072-1		JM27000425	SLIDE PIPE 630	2	X	Y06354		
073		JM27000082	FRONT RAIL	1				
074		JM27000085	KNOB NUT M10	1				
077A		JM27000088	FIX PLATE	1			Y08128	
077A1		JM00000147	TOOL CASE ASSY	1	<	Y08128		
078		JM27000089	SAW DUST OUTLET	1				
079		JM27000090	CUFFS 57-45	1				
080		JM27000091	HEX BOLT M6X65	1				
081		JM27000092	HEX BOLT M6X55	1				
082		JM27000093	CORD HANGER	2				
083		JM27000094	CORD GUARD	1				
084A		JM27000095	HOOK	2				
085		JM27000096	CROSS HEAD SCREW M5X25	6			Y08128	
085-1		JM27000156	PAN HEAD SCREW M5X20	6	X	Y08128		
087		JM27000102	CORD CLAMP	1				
088		JM27000103	TAPPING SCREW ST3.9X16	2				
089		JM27000104	HEX BOLT M10X45	1				
090A		JM27000105	CABINET	1			Y08128	
091		JM27000108	UNDER PANEL	1				
092		JM27000109	WASHER 4 (L)	1			Y08128	
092-1		JM27000009	FLAT WASHER 4	1	X	Y08128		
093		JM27000110	FRONT PANEL LABEL	1				
094		JM27000111	HEX BOLT M6X16	2				
095		JM27000112	BLADE CASE FIX BRACKET SPACER	1				
096A		JM27000113	MAKITA LOGO PLATE	1				
097		JM27000114	TAPPING SCREW ST2.9X10	2				
098		JM27000115	SOFT START DEVICE COVER	1				
100		JM27000117	TAPPING SCREW ST2.9X8	2				
101		JM27000118	CORD CLAMP	2			Y08128	
101-1		JM27000118	CORD CLAMP	1	<	Y08128		
102		JM27000119	SWITCH BOX COVER	1				
103		JM27000120	SWITCH BOX	1				
104A		JM27000121	CIRCUIT BREAKER 220-240V	1				
105		JM27000122	LABEL FOR CIRCUIT BREAKER	1				
106		JM27000123	NUT FOR CIRCUIT BREAKER	1				
107A		JM27000124	MAGNETIC SWITCH A (HV)	1			Y05745	
107A1		JM27000443	ANTI RESTART SWITCH 220-240V	1	<	Y05745		
108		JM27000136	PAN HEAD SCREW M4X14	2				
109		JM27000137	HEX SOCKET HEAD BOLT M6X12	1				
110		JM27000138	LOCK HANDLE FOR BLADE ANGLE	1				
111		JM27000139	BLADE ANGLE LOCKING BOLT	1				
112		JM27000140	COMPRESSION SPRING	1				
113		JM27000141	FLAT WASHER 10	1				
114		JM27000142	BLADE ANGLE ADJUSTING RACK	1				
115		JM27000143	SUPPORT PLATE FOR ADJUST RACK	1				
116		JM27000144	FLAT HEAD SCREW M5X8	4				
117A		JM27000145	RIP FENCE HOLDER	1				
119A		JM27000147	MOTOR ASSEMBLY 230V	1			Y05483	

A:

Interchange
O : Yes
X : No
< : the new part can be substituted for the current.
> : the current part can be substituted for the new.
S : Interchangeable as a set.

TH	THAILAND
----	----------

MLT100 / TABLE SAW 255MM

Item	Sub	Parts No.	Parts Description	Qty	I/C	E/C No.	Close No.	Remark
	D10		INC. 246-250,253,256,257,260,				Y05483	
	D20		INC. 262,263,319-322,431,				Y05483	
	D30		INC. 446-448,466,467				Y05483	
120		JM27000148	BRACKET FOR RIVING KNIFE	1			Y08907	
120-1		JM00000417	BRACKET FOR RIVING KNIFE	1	<	Y08907		
121		JM27000149	HEX SOCKET HEAD BOLT M6X20	2				
122		JM27000150	RIVING KNIFE	1			Y08201	
122-1		JM27000150	RIVING KNIFE	1	O	Y08201		
123		JM27000151	FIX PLATE FOR RIVING KNIFE	1			Y08907	
123-1		JM00000418	FIX PLATE FOR RIVING KNIFE	1	<	Y08907		
124		JM27000152	RETAINER PLATE FOR BLADE CASE	1				
125		JM27000153	BLADE CASE LEFT SIDE	1				
126		JM27000154	COVER PLATE FOR BLADE CASE	1				
127		JM27000155	FLAT WASHER 5	2				
128		JM27000156	PAN HEAD SCREW M5X20	2			Y08128	
128-1		JM27000156	PAN HEAD SCREW M5X20	4	<	Y08128		
129		JM27000157	SLIDE SHAFT FOR BLADE LIFTING	2				
130		JM27000158	SLIDE SCREW FOR BLADE LIFTING	1				
131		JM27000159	KEY 4X8	1				
132		JM27000160	BRACKET FOR SLIDE SCREW	1				
133		JM27000161	HEX SOCKET HEAD BOLT M5X20	2				
134		JM27000162	BEVEL GEAR FOR BLADE LIFTING	1				
135		JM27000163	RETAINING RING S-10	1				
136		JM27000164	BLADE ANGLE POINTER	1				
137		JM27000165	HANDLE AXLE FOR BLADE LIFTING	1				
138		JM27000166	ADJUSTING GRIP FOR BLADE ANGLE	1				
139		JM27000167	PAN HEAD SCREW M5X12	1				
140		JM27000168	CRANK ASSY FOR BLADE LIFTING	1			Y08132	
140-1		JM27000168	CRANK ASSY FOR BLADE LIFTING	1	O	Y08132		
	D10		INC. 141,593-596				Y08132	
141		JM27000169	PAN HEAD STEPPED SCREW M5X37	1				
142		JM27000170	PROTECTION PLATE	1				
143		JM27000171	INNER FLANGE 52	1				
144		JM27000172	H.S.SET SCREW M6X12 WITH GLUE	1				
145		JM27000173	SPRING FOR BLADE CASE BRACKET	2				
146		JM27000174	PAN HEAD SCREW M3X25	2				
147		JM27000175	WASHER 3 (L)	2				
148		JM27000176	HEX LOCK NUT M3	2				
149		JM27000177	TAPPING SCREW ST3.9X10	1				
150		JM27000178	PROTECTION PLATE 397X123	1				
151		JM27000179	OUTER FLANGE 52	1				
152		JM27000180	HEX NUT M16	1				
153		JM27000181	BLADE CASE RIGHT SIDE	1				
154		JM27000182	BLADE CASE PLATE	1				
155		JM27000183	HEX LOCK NUT M5	1				
156		JM27000184	SUPPORT BRACKET	1				
157		JM27000185	COVER	1			Y08128	
158		JM27000186	GRIP SCREW M8X10	1			Y08128	
158-1		JM27000186	GRIP SCREW M8X10	1	S	Y08128		
159		JM27000187	SPRING PIN 4X30	1				
160		JM27000188	KNURLED PIN 8X30	1				
161		JM27000189	ECCENTRIC RING	1				
162		JM27000190	FRICTION PAD	1				
163		JM27000191	KNURLED PIN 5X30	1				
164A		JM27000192	RIP FENCE BRACKET	1			Y08755	
164A1		JM00000264	RIP FENCE BRACKET	1	O	Y08755		
165		JM27000193	COMPRESSION SPRING	1				
166		JM27000194	RIP FENCE FIXED PLATE	1				
168		JM27000196	HEX BOLT M6X35	1				
169		JM27000197	POINTER	1				
170		JM27000198	PAN HEAD SCREW M4X8	1				
171		JM27000199	FENCE BRACKET	1				
172		JM27000200	FENCE END CAP	1				
173		JM27000201	FENCE BAR	1				
174		JM27000203	THUMB NUT M6	2				

A:

Interchange
O : Yes
X : No
< : the new part can be substituted for the current.
> : the current part can be substituted for the new.
S : Interchangeable as a set.

TH	THAILAND
----	----------

MLT100 / TABLE SAW 255MM

Item	Sub	Parts No.	Parts Description	Qty	I/C	E/C No.	Close No.	Remark
175		JM27000204	SQUARE NECK BOLT M6X60	2				
176		JM27000205	FENCE END CAP	1				
177		JM27000206	SLIDING BAR	1				
178		JM27000207	POINTER	1				
179		JM27000208	FLAT WASHER 3	1				
180		JM27000209	PAN HEAD SCREW M3X8	1				
181		JM27000210	THUMB SCREW M6X13	1				
182		JM27000211	WASHER 6 (L)	2				
183		JM27000212	WASHER 8	1				
184		JM27000213	THUMB SCREW M6X62	1				
185		JM27000214	SCALE LABEL	1				
186		JM27000215	GRIP SCREW M8X20	1			Y08128	
186-1		JM27000215	GRIP SCREW M8X20	1	S	Y08128		
187		JM27000216	WISE ROD	1				
188		JM27000217	THUMB SCREW M10X92	1				
189		JM27000218	WISE ARM	1				
190		JM27000219	WISE PLATE	1				
191		JM27000220	FENCE END CAP	2				
192		JM27000221	FENCE PLATE	1				
193		JM27000222	SQUARE NECK BOLT M6X30	2				
194A		JM27000223	ANGLE RULE BASE	1				
195		JM27000225	SLIDING BAR SPACER	1				
246		JM23000154	POWER SUPPLY CORD ASSY GAMBIA	1				
247		JM27000292	PAN HEAD SCREW M5X8	2				
248		JM27000293	AIR INLET COVER PLATE	1				
249		JM27000294	BRUSH CAP	2				
250		JM23000123	CARBON BRUSH 2PCS/SET	1				
251		JM27000296	BRUSH HOLDER	2			Y08132	
253		JM27000299	CORD CLAMP	1				
254		JM27000361	RUBBER RING	1				
255		JM27000301	BEARING 6001-2Z	1			Y05745	
255-1		JM27000445	BALL BEARING 6001RS	1	<	Y05745		
256A		JM27000302	STATOR ASSY 230V	1				
257		JM27000305	TAPPING SCREW ST4.8X70	2				
258A		JM27000306	ROTOR(230V)	1				
259		JM27000312	BEARING 6201-2Z	1			Y05745	
259-1		JM27000446	BALL BEARING 6201RS	1	<	Y05745		
260		JM27000313	BAFFLE RING	1				
261		JM27000314	GEAR BOX	1			Y05477	
261-1		JM27000423	GEAR BOX	1	<	Y05477	Y08128	
262		JM27000316	PAN HEAD SCREW M5X35	4				
263		JM27000317	FLAT HEAD SCREW M5X16	3				
264		JM27000318	BEARING BOX	1				
265		JM27000319	BALL BEARING 6003RS	1				
266		JM27000320	RETAINING RING R-35	1				
267		JM27000321	SPINDLE SHAFT 5/8"	1				
268		JM27000323	KEY 5X6.5X16	1				
269		JM27000324	HELICAL GEAR 43	1				
270		JM27000325	RETAINING RING S-16	1				
271		JM27000326	BUSH	1			Y08128	
272		JM27000327	SLIDING TABLE BASE FIX PLATE	2				
275		JM27000330	HOOK	1			Y08128	
277		JM27000332	R-TYPE CABLE CLAMP	2				
278		JM27080019	NAME PLATE	1				
280A		JM27000333	SCALE LABEL (METRIC)	1				
281A		JM27000335	SCALE LABEL EX-TABLE (METRIC)	1				
283A		JM27000337	SCALE LABEL	2			Y06354	
283A1		JM27000428	SCALE LABEL SL-PIPE (METRIC)	2	X	Y06354		
284		JM27000339	H.S.SET SCREW M6X20 WITH GLUE	2				
285		JM27000340	BLADE GUARD	1				
286		JM27000341	CROSS HEAD SELF TAPPING SCREW	4			Y08132	
286-1		JM27000114	TAPPING SCREW ST2.9X10	4	X	Y08132		
287		JM27080020	WARNING LABEL	1				
288		JM27080060	WARNING LABEL	1				
309A		JM27000052	UP BLADE GUARD ASSEMBLY (EU TY	1				

A:

Interchange
 O : Yes
 X : No
 < : the new part can be substituted for the current.
 > : the current part can be substituted for the new.
 S : Interchangeable as a set.

TH	THAILAND
-----------	-----------------

MLT100 / TABLE SAW 255MM

Item	Sub	Parts No.	Parts Description	Qty	I/C	E/C No.	Close No.	Remark
	D10		INC. 49-60,122,285,286,288				Y08132	
	D11		INC. 49-60,122,285,286,288,597			Y08132		
310A		JM27000076	SUB FRONT RAIL ASSEMBLY (MMSCA)	1				
	D10		INC. 70,281					
311A		JM27000080	SLIDING BAR A ASSEMBLY (MMSCAL)	1			Y06354	
	D10		INC. 72,283				Y06354	
311A1		JM27000426	SLIDING BAR A ASSEMBLY (MMSCAL)	1	X	Y06354		
	D10		INC. 72,283			Y06354		
312A		JM27000083	FRONT RAIL ASSEMBLY (MMSCALE)	1				
	D10		INC. 73,280					
313B		JM27000101	BLADE INNER LING 25.4	1				
314A		JM27000106	CABINET	1				
315D		JM27000130	SWITCH ASSY 4 SWA SOX CAX	1				
	D10		INC. 97,98,100-108,430,498					
316A		JM27000202	RIP FENCE ASSEMBLY	1				
	D10		INC. 121,158-166,168-173,175,				Y08128	
	D11		INC. 121,158,162,169-173,175,			Y08128		
	D20		INC. 176,418,435,458,484,500,				Y08128	
	D21		INC. 176,418,435,458,484,500,			Y08128		
	D30		INC. 501,521				Y08128	
	D31		INC. 501,565			Y08128		
317A		JM27000224	MITER GUAGE ASSEMBLY	1				
	D10		INC. 92,157,174,177-195,452,				Y08128	
	D11		INC. 92,174,177-195,452,483,			Y08128		
	D20		INC. 483,485,523				Y08128	
	D21		INC. 485,523,582			Y08128		
319		JM27000298	MOTOR HOUSE ASSEMBLY	1			Y08132	
	D10		INC. 251				Y08132	
319-1		JM00000150	MOTOR HOUSING ASSY	1	O	Y08132		
320A		JM27000309	ARMATURE ASSY 230V	1				
	D10		INC. 254,255,258,259					
321		JM27000315	GEAR BOX ASSEMBLY	1			Y05483	
	D10		INC. 261,271				Y05483	
321-1		JM27000424	GEAR BOX ASSEMBLY	1	<	Y05483		
	D10		INC. 261,271			Y05483	Y08128	
322		JM27000322	OUTER SHAFT ASSEMBLY	1				
	D10		INC. 264-270					
411		JM27000024	FLAT WASHER 6	12				
412		JM27000024	FLAT WASHER 6	12				
413		JM27000024	FLAT WASHER 6	2			Y08128	
414		JM27000024	FLAT WASHER 6	2				
415		JM27000024	FLAT WASHER 6	2				
416		JM27000024	FLAT WASHER 6	2				
417		JM27000024	FLAT WASHER 6	2				
418		JM27000024	FLAT WASHER 6	2				
424		JM27000004	SELF TAPPING SCREW ST3.9X12	2				
426		JM27000004	SELF TAPPING SCREW ST3.9X12	2			Y08128	
426-1		JM27000177	TAPPING SCREW ST3.9X10	4	X	Y08128		
427		JM27000004	SELF TAPPING SCREW ST3.9X12	2				
428		JM27000004	SELF TAPPING SCREW ST3.9X12	6				
429		JM27000004	SELF TAPPING SCREW ST3.9X12	2				
430		JM27000004	SELF TAPPING SCREW ST3.9X12	2				
431		JM27000004	SELF TAPPING SCREW ST3.9X12	2				
432		JM27000009	FLAT WASHER 4	4				
433		JM27000009	FLAT WASHER 4	1			Y08128	
433-1		JM27000009	FLAT WASHER 4	1	O	Y08128		
434		JM27000009	FLAT WASHER 4	1			Y08128	
434-1		JM27000009	FLAT WASHER 4	1	O	Y08128		
435		JM27000009	FLAT WASHER 4	1				
437		JM27000009	FLAT WASHER 4	2				
438		JM27000009	FLAT WASHER 4	2				
439		JM27000009	FLAT WASHER 4	2				
440		JM27000009	FLAT WASHER 4	1				
441		JM27000155	FLAT WASHER 5	2			Y08128	
441-1		JM27000155	FLAT WASHER 5	4	<	Y08128		

A:

Interchange
O : Yes
X : No
< : the new part can be substituted for the current.
> : the current part can be substituted for the new.
S : Interchangeable as a set.

TH	THAILAND
----	----------

MLT100 / TABLE SAW 255MM

Item	Sub	Parts No.	Parts Description	Qty	I/C	E/C No.	Close No.	Remark
442		JM27000155	FLAT WASHER 5	2				
443		JM27000155	FLAT WASHER 5	1			Y08128	
444		JM27000155	FLAT WASHER 5	1				
445		JM27000155	FLAT WASHER 5	2			Y08128	
446		JM27000155	FLAT WASHER 5	4				
447		JM27000155	FLAT WASHER 5	2				
448		JM27000155	FLAT WASHER 5	2				
449		JM27000016	PAN HEAD SCREW M6X10	3				
450		JM27000033	HEX BOLT M6X10	3				
451		JM27000013	SPRING WASHER 4	4				
452		JM27000013	SPRING WASHER 4	1				
453		JM27000013	SPRING WASHER 4	2				
454		JM27000013	SPRING WASHER 4	2				
455		JM27000013	SPRING WASHER 4	1				
457		JM27000017	SPRING WASHER 6	3			Y08128	
457-1		JM27000024	FLAT WASHER 6	3	X	Y08128		
458		JM27000017	SPRING WASHER 6	2				
459		JM27000017	SPRING WASHER 6	2				
460		JM27000017	SPRING WASHER 6	2				
461		JM27000017	SPRING WASHER 6	2				
462		JM27000032	HEX NUT M6	1				
463		JM27000048	SPRING WASHER 5	2			Y08128	
463-1		JM27000048	SPRING WASHER 5	4	<	Y08128		
464		JM27000048	SPRING WASHER 5	2				
465		JM27000048	SPRING WASHER 5	1			Y08128	
466		JM27000048	SPRING WASHER 5	4				
467		JM27000048	SPRING WASHER 5	2			Y08128	
468		JM27000042	PAN HEAD SCREW M5X10	2				
469		JM27000042	PAN HEAD SCREW M5X10	2				
470		JM27000042	PAN HEAD SCREW M5X10	2				
471		JM27000042	PAN HEAD SCREW M5X10	2			Y08201	
471-1		JM27000042	PAN HEAD SCREW M5X10	1	O	Y08201		
472		JM27000042	PAN HEAD SCREW M5X10	1				
473		JM27000109	WASHER 4 (L)	2				
474		JM27000109	WASHER 4 (L)	6				
475		JM27000109	WASHER 4 (L)	2				
476		JM27000109	WASHER 4 (L)	1				
477		JM27000011	PAN HEAD SCREW M4X12	4				
478		JM27000011	PAN HEAD SCREW M4X12	1				
479		JM27000011	PAN HEAD SCREW M4X12	1				
480		JM27000011	PAN HEAD SCREW M4X12	2				
481		JM27000047	WASHER 5 (L)	6				
482		JM27000047	WASHER 5 (L)	2				
483		JM27000066	FLAT HEAD SCREW M4X8	2				
484		JM27000066	FLAT HEAD SCREW M4X8	1				
485		JM27000027	PAN HEAD SCREW M4X10	1				
486		JM27000027	PAN HEAD SCREW M4X10	2				
487		JM27000027	PAN HEAD SCREW M4X10	2				
488		JM27000027	PAN HEAD SCREW M4X10	1				
489		JM27000037	TAPPING SCREW ST3.9X8	3				
490		JM27000149	HEX SOCKET HEAD BOLT M6X20	2				
491		JM27000149	HEX SOCKET HEAD BOLT M6X20	2				
492		JM27000070	HEX NUT M8	2				
493		JM27000071	SPRING WASHER 8	2				
494		JM27000072	FLAT WASHER 8	2				
495		JM27000073	SQUARE NECK BOLT M8X25	2				
496		JM27000038	PAN HEAD SCREW M6X16	2				
497		JM27000043	KNOB BOLT M6X20	2				
498		JM27000114	TAPPING SCREW ST2.9X10	2				
500		JM27000203	THUMB NUT M6	2				
501		JM27000211	WASHER 6 (L)	2				
504		JM27000051	HEX LOCK NUT M6	2			Y08128	
504-1		JM27000032	HEX NUT M6	2	X	Y08128		
505		JM27000005	GRIP (OUTSIDE)	1			Y08191	
505-1		JM27000006	GRIP (INSIDE)	1	X	Y08191		

A:

Interchange
O : Yes
X : No
< : the new part can be substituted for the current.
> : the current part can be substituted for the new.
S : Interchangeable as a set.

