



TH	THAILAND
----	----------

# Diagram / Parts List

**DTD154**

**CORDLESS IMPACT DRIVER**



(TH) DTD154 / CORDLESS IMPACT DRIVER

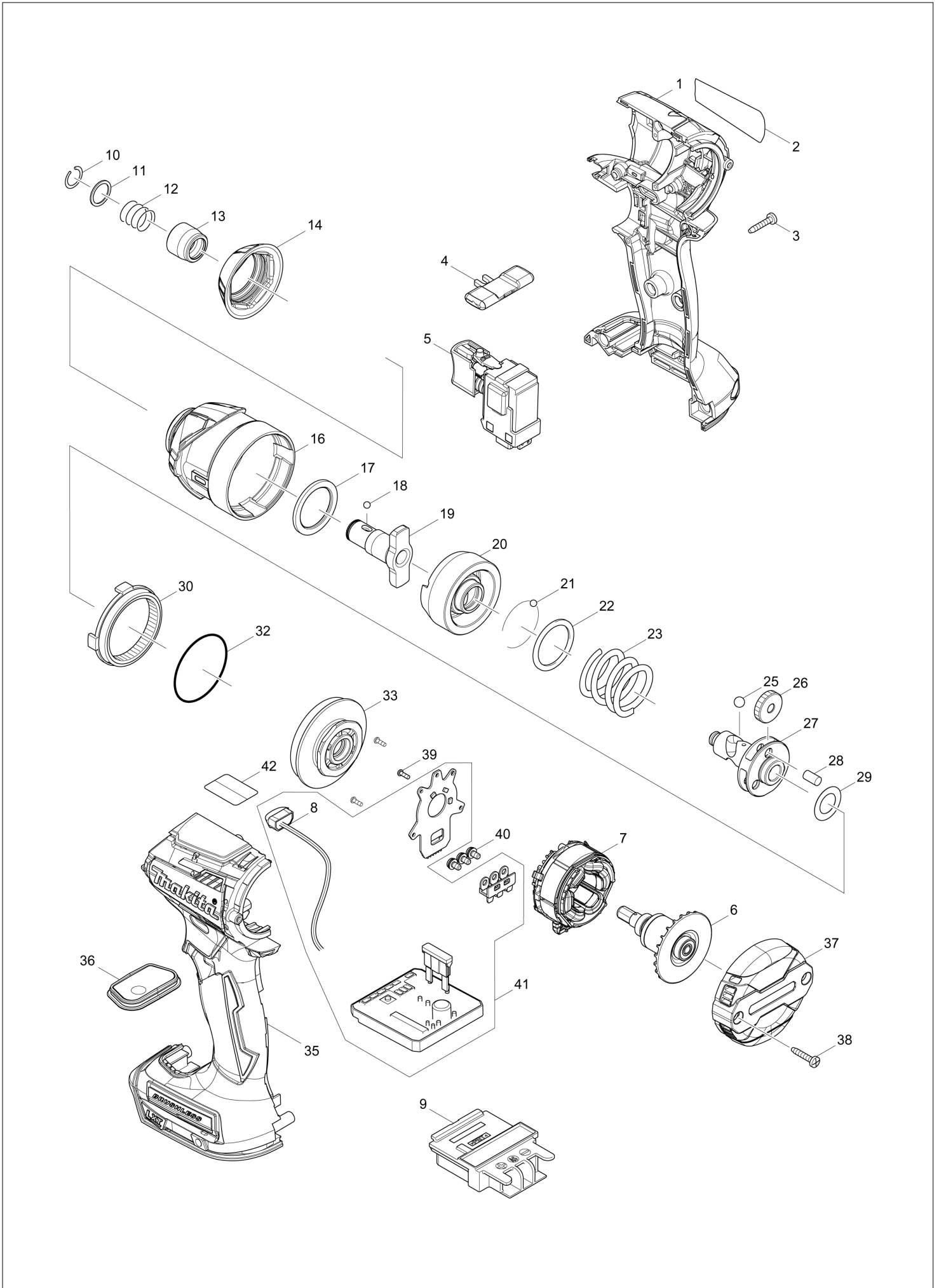

TH	THAILAND
----	----------

### DTD154 / CORDLESS IMPACT DRIVER

Item	Sub	Parts No.	Parts Description	Qty	I/C	E/C No.	Close No.	Remark
001		183E36-5	HOUSING SET	1				
	C10	263005-3	RUBBER PIN 6	2				
	C20	252126-6	HEX. LOCK NUT M4-7	2				
	D10		INC. 35					
002		852L16-1	DTD154 NAME PLATE	1			D2622	
002-1		857J30-0	DTD154 NAME PLATE	1	S	D2622		
003		266429-2	TAPPING SCREW 3X16	8				
004		455053-8	F/R CHANGE LEVER	1				
005		143975-1	SWITCH COMPLETE	1				
006		619408-3	ROTOR	1				
007		629217-2	STATOR	1				
008		620557-1	LED CIRCUIT	1				
009		643860-3	TERMINAL	1				
010		231951-8	RING SPRING 11	1				
011		267085-1	FLAT WASHER 12	1				
012		233005-7	COMPRESSION SPRING 13	1				
013		326072-0	BIT SLEEVE	1				
014		424873-1	BUMPER	1				
016		143951-5	HAMMER CASE COMPLETE	1				
017		261155-8	NYLON WASHER 24	1				
018		216001-0	STEEL BALL 3.5	2			D0295	
018-1		216040-0	STEEL BALL 3.5	2	O	D0295		
019		326507-1	ANVIL N	1				
020		326711-2	HAMMER	1			C1529	
020-1		327155-9	HAMMER	1	O	C1529		
021		216001-0	STEEL BALL 3.5	24			D0295	
021-1		216040-0	STEEL BALL 3.5	24	O	D0295		
022		267175-0	FLAT WASHER 24	1				
023		234331-7	COMPRESSION SPRING 24	1				
025		216041-8	STEEL BALL 5.6	2				
026		227338-0	SPUR GEAR 22	3				
027		326783-7	SPINDLE	1				
028		268311-1	PIN 5	3				
029		253314-8	THIN WASHER 15	1				
030		221457-4	INTERNAL GEAR 51	1				
032		213507-9	O RING 40	1				
033		143976-9	BEARING BOX COMPLETE	1				
035		183E36-5	HOUSING SET	1				
	C10	263005-3	RUBBER PIN 6	2				
	C20	252126-6	HEX. LOCK NUT M4-7	2				
	D10		INC. 1					
036		143954-9	SWITCH PLATE COMPLETE	1				
037		457069-9	REAR COVER	1				
038		266429-2	TAPPING SCREW 3X16	2				
039		266490-9	TAPPING SCREW PT 2X6	3				
040		652069-6	FLAT HEAD SCREW M3X6	3				
041		620564-4	CONTROLLER	1				
	D10		INC. 8					
043		857J31-8	DTD154 SERIAL NO. LABEL	1	S	D2622		
A01		266622-8	+ TRUSS HEAD SCREW M4X12	1				
A02A		346317-0	HOOK	1				
A02B		346317-0	HOOK	1				
A02C		346317-0	HOOK	1				
A02D		346449-3	HOOK	1				
A03B		450128-8	BATTERY COVER	1				
A03C		450128-8	BATTERY COVER	1				
A03D		450128-8	BATTERY COVER	1				
A04B		***DC18RC	DC18RC FAST CHARGER	1				
	D10		COMPO-PARTS					
A04C		***DC18RC	DC18RC FAST CHARGER	1				
	D10		COMPO-PARTS					
A04D		***DC18RC	DC18RC FAST CHARGER	1				
	D10		COMPO-PARTS					
A05B		197600-6	BATTERY BL1830B SET	2			C2803	
A05C		197280-8	BATTERY BL1850B SET	2			C2803	

A:DTD154Z(N)  
 B:DTD154RFE(H)  
 C:DTD154RTE(H)  
 D:DTD154RYE(H)

Interchange  
 O : Yes  
 X : No  
 < : the new part can be substituted for the current.  
 > : the current part can be substituted for the new.  
 S : Interchangeable as a set.

