



TH	THAILAND
----	----------

# Diagram / Parts List

**DVC665**

**DC BACKPACK VACUUM CLEANER**



(TH) DVC665 / DC BACKPACK VACUUM CLEANER

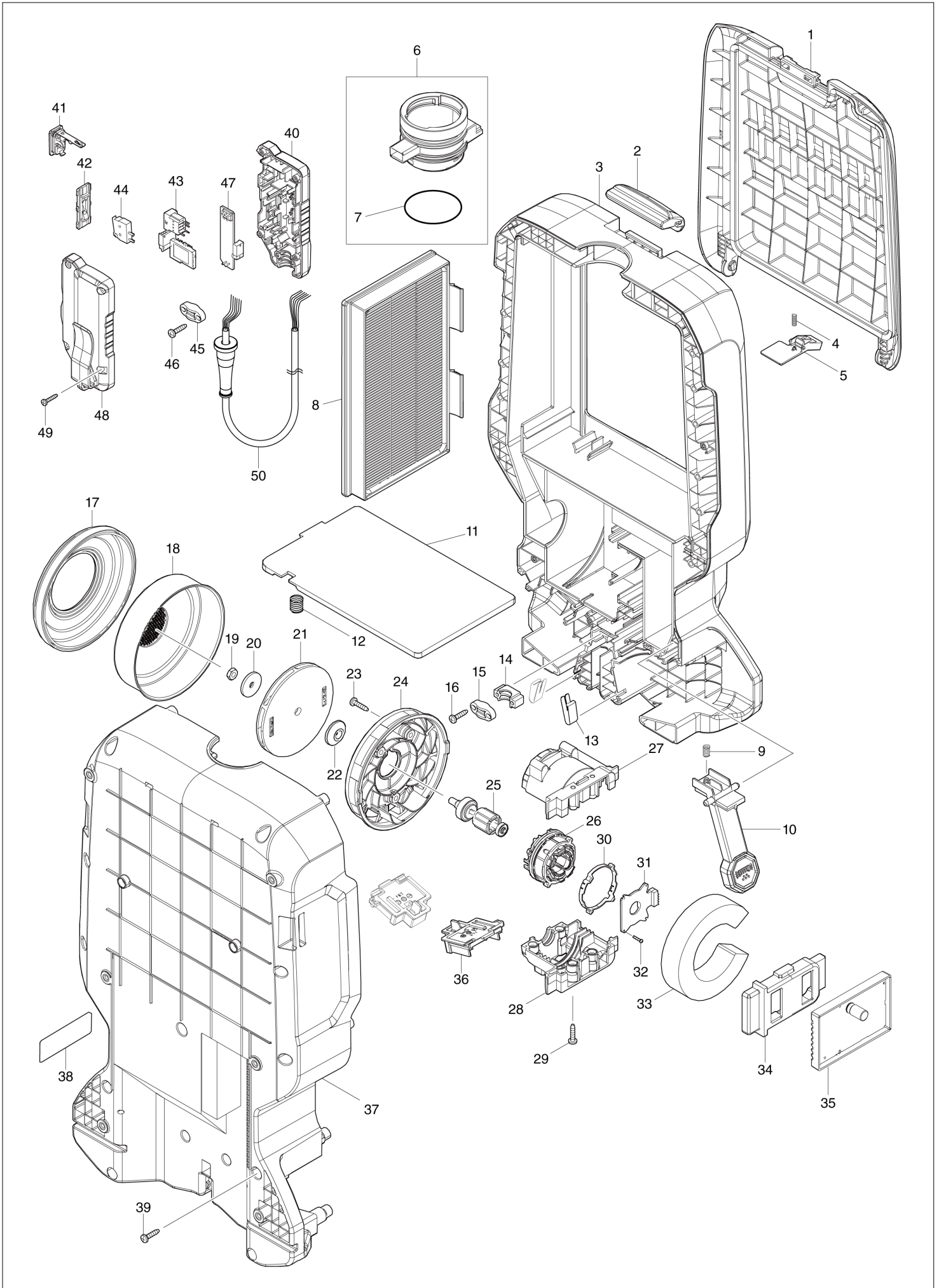

(TH) DVC665 / DC BACKPACK VACUUM CLEANER

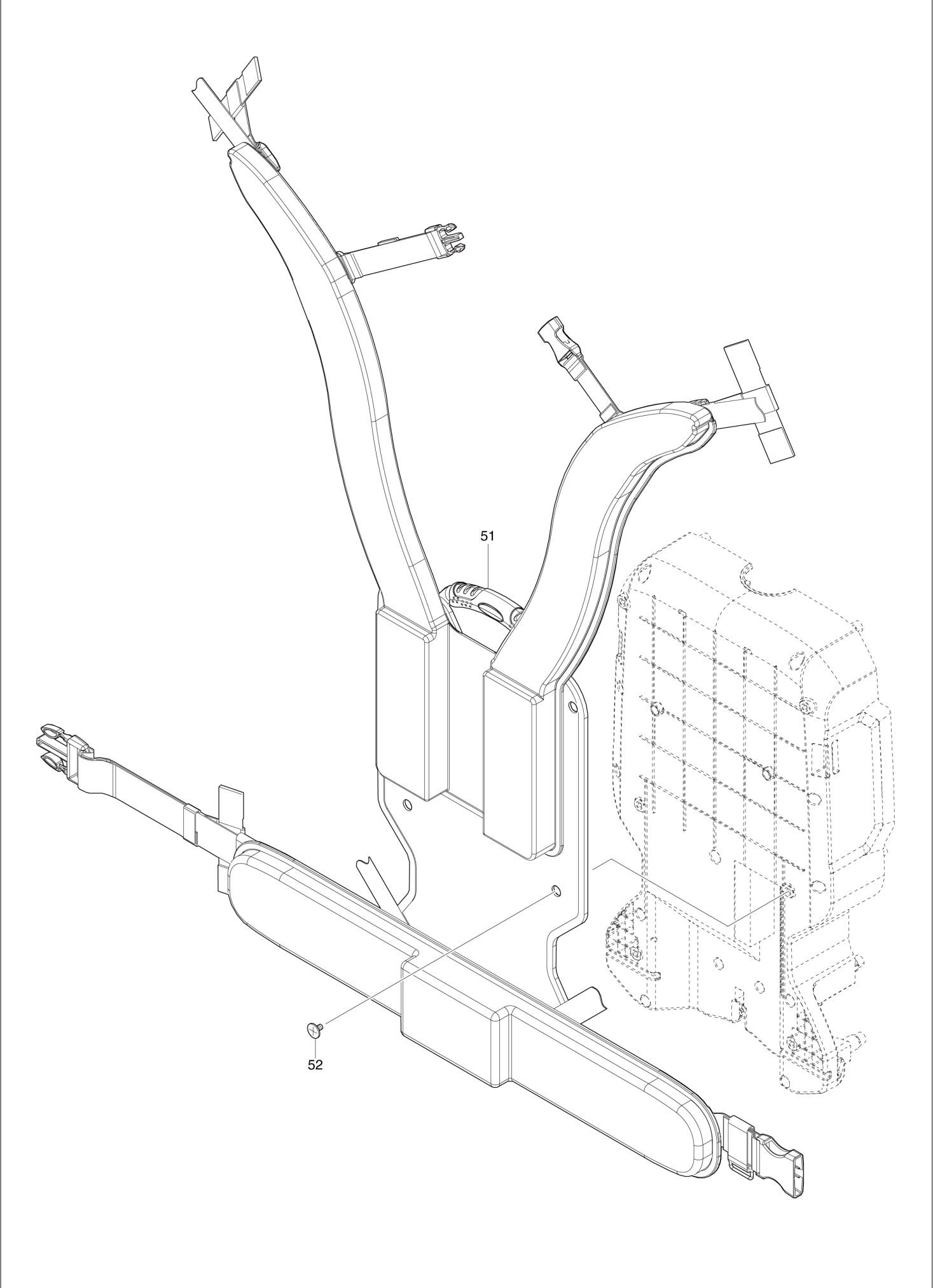

TH	THAILAND
----	----------

### DVC665 / DC BACKPACK VACUUM CLEANER

Item	Sub	Parts No.	Parts Description	Qty	I/C	E/C No.	Close No.	Remark
001		140P98-2	DUST BOX COVER COMPLETE	1				
	C10	422536-3	SEAL A	1				
002		123586-8	LATCH ASSEMBLY	1				
003		140P92-4	UPPER HOUSING COMPLETE	1				
	C10	422534-7	BAND DAMPER D	1				
	C20	422550-9	BAND DAMPER A	1				
004		232389-0	COMPRESSION SPRING 5	1				
005		412268-0	STOPPER PLATE	1				
006		135771-1	INLET ASS'Y	1				
	D10		INC. 7					
007		213655-4	O RING 56	1				
008		191D12-9	MAIN FILTER H SET	1				
009		232588-4	COMPRESSION SPRING 6	1				
010		140P99-0	LEVER 100 COMPLETE	1				
011		459913-6	PLATE	1				
012		234141-2	COMPRESSION SPRING 12	2				
013		232267-4	LEAF SPRING	2				
014		687051-6	STRAIN RELIEF	1				
015		687123-7	STRAIN RELIEF	1				
016		266326-2	TAPPING SCREW 4X18	2				
017		422376-9	SUPPORT RING	1				
018		161804-6	FAN COVER	1				
019		252268-6	HEX. NUT M6	1				
020		322407-3	WASHER 6	1				
021		241851-4	FAN 94	1				
022		313062-2	FLANGE	1				
023		266326-2	TAPPING SCREW 4X18	3				
024		456736-3	FAN BASE	1				
025		619517-8	ROTOR	1				
026		629381-9	STATOR	1				
027		183D13-1	MOTOR HOUSING SET	1				
	D10		INC. 28					
028		183D13-1	MOTOR HOUSING SET	1				
	D10		INC. 27					
029		266326-2	TAPPING SCREW 4X18	4				
030		687464-1	SUPPORT	1				
031		620526-2	CONTROLLER B	1				
032		266786-8	+ PAN HEAD TAPPING SCREW 2X10	4				
033		422370-1	BAND DAMPER C	1				
034		424837-5	SUPPORT A	1				
035		620C53-7	CONTROLLER	1				
036		644809-6	TERMINAL	2				
037		140P94-0	LOWER HOUSING COMPLETE	1				
	C10	422535-5	BAND DAMPER E	1				
	C20	422551-7	BAND DAMPER B	1				
038		856K60-4	DVC665 NAME PLATE	1				
039		266326-2	TAPPING SCREW 4X18	13				
040		183K75-1	SWITCH CASE SET	1				
	C10	818F55-5	SWITCH LABELA	1				
	C20	818F56-3	SWITCH LABELB	1				
	D10		INC. 48					
041		140G18-2	CAP COMPLETE	1				
	C10	213218-6	O RING 16	1			DA223	
	C11	213A05-9	O-RING16	1	O	DA223		
	C20	818F57-1	CAP LABEL	1				
042		458714-9	SWITCH LEVER	1				
043		620943-6	SUB CONTROLLER	1				
044		632E26-0	SWITCH UNIT	1				
045		687123-7	STRAIN RELIEF	1				
046		266326-2	TAPPING SCREW 4X18	2				
047		620949-4	SWITCH CIRCUIT	1				
048		183K75-1	SWITCH CASE SET	1				
	C10	818F55-5	SWITCH LABELA	1				
	C20	818F56-3	SWITCH LABELB	1				
	D10		INC. 40					

Interchange  
O : Yes  
X : No  
< : the new part can be substituted for the current.  
> : the current part can be substituted for the new.  
S : Interchangeable as a set.

